



Gunnebo GlasStile S

Motorised Entrance Gate for Internal Installation

Entrance Gates are designed to combine smooth function and sophisticated appearance with security needs in settings where design is important. The Entrance Gates provide easy passage and high throughput. Designed to reduce the barrier effect and create a welcome atmosphere, visitors can immediately see how and where they should enter.

GlasStile S consists of a grained stainless steel column with one glass leaf.

A wide selection of glass dimensions and styles is available to create a two-leaf passage or match with the design of the SpeedStile product range.

On receiving the signal from the access control system or push button, the unit will unlock and drive through 90° away from the signal direction. On detection of an obstruction, the leaf will immediately stop. An auto-reset will re-establish control.

Technical Specifications

Drive

Motorised, pass left or pass right. Logic Voltage 24Vac

Materials

Rotor column: 304 grade grained stainless steel

Rotor wing: 10mm-thick clear toughened frameless glass leaf

Top Lid: Black anodised aluminium

Status Light

LED positioned at the top of the column signals the passage status for each direction:

Blue: Awaiting Authorisation

Green: Passage Authorised

Red: No Passage Allowed

Power Failure / Fire Alarm

In the event of an emergency or isolation of power supply, the unit will fail-safe unlocked i.e. rotor will freely turn in both directions when pushed. Input facility available for voltage free contact supplied by others to effect fire alarm fail-safe state.

Additional reader housing available installed on top of the column to house RFID reader.

Additional Interface

Potential-free contact provided by either a card reader or push button input. Card reader inhibit and reset output signals are available as standard.

Technical Data

Dimensions	See details on next page
Power Supply	230Vac 50 Hz or 115Vac 60 Hz
Power Rating	120VA
Operating Temperature	+5 to +40 °C (RH 95% not condensing)
IP rating / MCBF / MTTR	IP 20 / 1M cycles / less than 30 min
Flow Rates (approximate figures):	Insertion Type Reader: 10 passages per minute Swipe Type Reader: 15 passages per minute Proximity Reader: "Hands Free": 20 passages per minute

Models

1000mm High Plain Column

Options

Alternative finishes

Glass leaf height and width selection

Push button control

Remote console

Remote control system

Benefits

- Smooth function and sophisticated appearance
- Operation providing easy passage and high throughput
- Designed to reduce the barrier effect
- Small footprint
- Wide range of barrier heights and passage widths available

Applications

Government

Retail

Finance

Telecommunications

IT

Banking

Publishing

Leisure

Petrochemical

Education

Models and configurations: GlasStile S

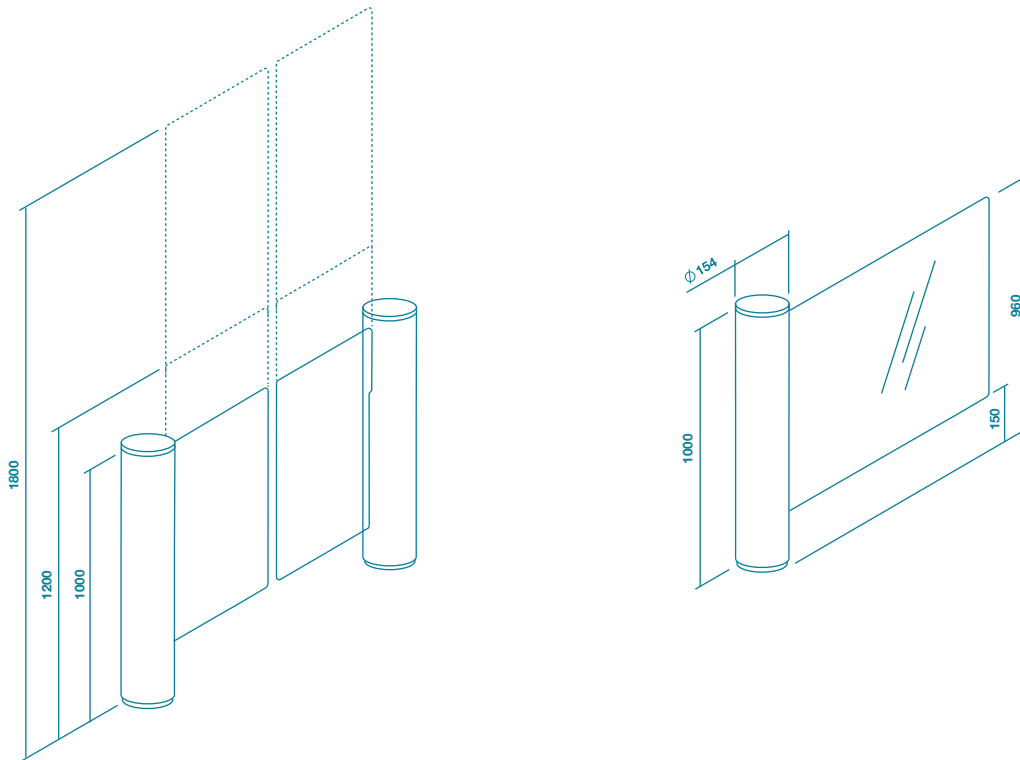

Height (mm)	Maximum glass leaf width (mm)
960	1150 (1200mm clear opening)
1200	1000 (1050mm clear opening)
1800	975 (1025mm clear opening)



Reader housing installed on GlasStile S

Important: Any horizontal pipe or conduit running below the GlasStile must be at least 140mm below FFL. Metal conduit for cables should be raised at least 50mm from foundation. It is the customer's responsibility to ensure the structural integrity and strength of the installation location. The dimensions given in this Product Data Sheet are for information only. In order to prepare the installation site, please refer to your usual Gunnebo Customer Service contact.

Conditions of use: When using Gunnebo's security access control gates, for security and safety reasons, children must be supervised by an adult at all times.

Gunnebo GlasStile S



Take advantage of our knowledge:
www.gunneboentrancecontrol.com

GUNNEBO[®]
Entrance Control